



**Istituto per le Tecnologie
della Costruzione
Consiglio Nazionale delle Ricerche**

Via Lombardia 49 - 20098 San Giuliano Milanese – Italy
tel: +39-02-9806.1 – Telefax: +39-02-98280088
e-mail: segreteria.itab@itc.cnr.it



Member of



www.eota.eu
European Organisation for
Technical Assessment
Organisation Européenne
pour l'évaluation technique

European Technical Assessment ETA 21/1008 of 22/03/2022

GENERAL PART

Trade name of the construction product

Pannello singolo portante Nidyon

Product family to which the construction product belongs

**PAC 34: BUILDING KITS, UNITS,
PREFABRICATED ELEMENTS.
Panels of steel wires with incorporated
thermal insulation for a whole structure**

Manufacturer

**NIDYON S.r.l.
Via Cesare Cantù, 47 – 47891 Dogana
Repubblica di San Marino**

Manufacturing plant

**NIDYON S.r.l.
Via dei Cerri, 28 – 47899 Serravalle
Repubblica di San Marino**

This European Technical Assessment contains:

**20 pages, including 9 annexes which form an
integral part of this assessment**

This European Technical Assessment is issued in accordance with Regulation (EU) n° 305/2011, on the basis of

**EAD 340002-00-0204 – Panels of steel wires
with incorporated thermal insulation for a
whole structure**

The European Technical Assessment is issued by ITC-CNR in Italian and English language. Translations of this European Technical Assessment into other languages shall fully correspond to the original issued document and should be identified as such. Communication of this European Technical Assessment, including transmission by electronic means, shall be in full (excepted the confidential Annex(es) referred to above). However, partial reproduction can be made with the written consent of ITC-CNR (issuing Technical Assessment Body). In this case partial reproduction has to be designated as such.

SPECIFIC PARTS

1. TECHNICAL DESCRIPTION OF THE PRODUCT

The product **Pannello singolo portante Nidyon** is a kit composed of:

- a 3-dimensional grid of two welded fabrics of steel wires jointed with connectors of steel wire welded to the fabrics;
- thermal insulation material of expanded polystyrene (EPS) between the two welded fabrics, penetrated by the connectors.

The panels are manufactured in standardised widths equal to 1120 mm, height variable depending on the building inter-storey, and they are characterized by a wave-shaped cross-section profile whose thickness ranges between 60 mm and 160 mm. The welded fabrics and the connectors are realized by galvanized steel wires with yield strength equal or higher than 700 MPa. The diameter of the welded fabrics is equal to 2.5 mm and their spacing is equal to 50 x 50 mm. The diameter of the steel connectors is equal to 3.0 mm. 47 connectors per square meter are installed.

On site, the panels are arranged next to each other (according to design layouts) on a substructure (generally in ordinary concrete) flat and carefully levelled out before placing the panels. Special care is taken about the joints between the cores of expanded polystyrene, in order to avoid remaining gap between them, and the vertical alignment. All that to ensure equal thickness of shotcrete over the whole wall and to avoid thermal bridges within the wall. Splice bars are generally installed in the substructure for structural connection of the panels. The installed panels are completed on site with additional components, such as additional reinforcing steel which can be tied to the welded fabric to enhance the structural performance of the structure, strips, and sheets of welded fabric for connections of corners or for windows and doors. The additional reinforcing steel is not part of the kit. On both sides of the panels, concrete is applied with the shotcrete technique, covering the welded fabrics and, if applicable, the additional reinforcing steel, until an average thickness of 40 mm is reached. Shotcrete is not part of the kit.

External and internal finishes, auxiliary devices to fix non-structural components and any additional components are not part of the kit.

The product description, with reference to its components, is given in Annex A.

2. SPECIFICATION OF THE INTENDED USE IN ACCORDANCE WITH EUROPEAN ASSESSMENT DOCUMENT N° 340002-00-0204 (hereinafter EAD)

The **Pannello singolo portante Nidyon** is intended to be used as internal and external walls for the construction of structures, typically for buildings, which may be above or below ground, and their joints. The structure is completed on site with reinforcing steel, if required, and with shotcrete. Reinforcing steel and shotcrete have both a structural function within the structure but are not part of the kit. The structure constructed with the panels is subjected to only static, quasi-static, and seismic actions. The kit is intended to be used as a structural part of dissipative structures in seismic areas.

Concerning product packaging, transport and storage it is the responsibility of the manufacturer to undertake the appropriate measures and to advise his clients on the transport and storage, as he considers necessary in order to reach the declared performances.

The information about installation is provided with the technical documentation from the Manufacturer and it is assumed that the product will be installed according to it or (in absence of such instructions) according to the usual practice of the building professionals.

The specifications and conditions given by the manufacturer are summarized in Annex B.

The performances assessed in this European Technical Assessment, according to the applicable EAD, are based on an assumed intended working life of at least 50 years, provided that the conditions for packaging, transport, storage, installation as well as appropriate use, maintenance and repair are met. The indications given on the working life cannot be interpreted as a guarantee given by the manufacturer, but are to be regarded only as a means for choosing the right products in relation to the expected economically reasonable working life of the works.

3. PERFORMANCE OF THE PRODUCT AND REFERENCES TO THE METHODS USED FOR ITS ASSESSMENT

The performance assessment of **Pannello singolo portante Nidyon** was carried out in compliance with EAD 340002-00-0204 according to the methods reported herein.

The resulting performances in relation to the essential characteristics are given in Table 3.1 for the whole kit and in Table 3.2, Table 3.3, and Table 3.4, for the different components of the kit.

The numbering (#) in the following tables corresponds to the numbering of Table 1, Table 2, Table 3, and Table 4 of EAD 340002-00-0204.

Table 3.1 – Essential characteristics and performances of the whole kit.

#	Essential characteristic	Performance
Mechanical resistance and stability (BWR 1)		
1	Shape of panels	Conform to technical drawings (as reported in Annex A1).
2	Dimensions of panels	Conform to panel specifications on dimensions and tolerances (as reported in Annex A1).
3	Resistance to flexure	See Annex C1
4	Resistance to shear	See Annex C2
5	Resistance to compression	See Annex C3
6	Resistance to concentrated loads	NPA ⁽¹⁾
7	Long term loading	NPA
8	Resistance to seismic actions	See Annex C1
9	Resistance to corrosion	NPA
Safety in case of fire (BWR2)		
10	Reaction to fire	NPA
11	Resistance to fire	NPA
12	Vapour permeability	NPA
Safety and accessibility in use (BWR4)		
13	Same as BWR 1, except resistance to seismic actions (No 8).	
Protection against noise (BWR5)		
14	Airborne sound insulation	NPA
Energy economy and heat retention (BWR6)		
15	Thermal resistance	NPA
16	Thermal inertia	NPA
17	Air tightness	NPA

⁽¹⁾ NPA = No Performance Assessed.

Table 3.2 – Essential characteristics and performances of the welded fabric.

#	Essential characteristic	Performance
Mechanical resistance and stability (BWR 1)		
1	Mechanical characteristics	NPA ⁽¹⁾
2	Weld shear force	NPA
3	Bending	NPA
4	Dimensions	NPA
5	Mass	NPA
6	Resistance to corrosion	NPA
Safety in case of fire (BWR2)		
7	Reaction to fire	NPA
Safety and accessibility in use (BWR4)		
8	Same as BWR 1	

⁽¹⁾ NPA = No Performance Assessed.

Table 3.3 – Essential characteristics and performances of the steel connectors.

#	Essential characteristic	Performance
Mechanical resistance and stability (BWR 1)		
1	Mechanical characteristics	NPA ⁽¹⁾
2	Weld shear force	NPA
3	Dimensions	NPA
4	Mass	NPA
5	Resistance to corrosion	NPA
Safety in case of fire (BWR2)		
6	Reaction to fire	NPA
Safety and accessibility in use (BWR4)		
7	Same as BWR 1	
Energy economy and heat retention (BWR6)		
8	Thermal conductivity	NPA
9	Thermal inertia	NPA

⁽¹⁾ NPA = No Performance Assessed.

Table 3.4 – Essential characteristics and performances of the thermal insulation material

#	Essential characteristic	Performance
Mechanical resistance and stability (BWR 1)		
1	Dimensional stability	NPA ⁽¹⁾
2	Compressive creep	NPA
3	Compressive stress at 10% deformation	NPA
4	Shear behaviour	NPA
Safety in case of fire (BWR2)		
5	Reaction to fire	NPA
Hygiene, health, and the environment (BWR3)		
6	Water vapour transmission	NPA
Safety and accessibility in use (BWR4)		
7	Same as BWR 1	
Energy economy and heat retention (BWR6)		
8	Apparent density	NPA
9	Bending strength	NPA
10	Shape	NPA
11	Dimensions	NPA
12	Squareness	NPA
13	Thermal conductivity	NPA

⁽¹⁾ NPA = No Performance Assessed.

4. ASSESSMENT AND VERIFICATION OF CONSTANCY OF PERFORMANCE (AVCP) SYSTEM APPLIED, WITH REFERENCE TO ITS LEGAL BASE

In accordance with the European Assessment Document EAD No. 340002-00-0204 the applicable European legal act is **Decision 2003/728/EC**.
The AVCP system to be applied is: 1.

5. TECHNICAL DETAILS NECESSARY FOR THE IMPLEMENTATION OF THE AVCP SYSTEM, AS PROVIDED FOR IN EAD 340002-00-0204

Technical details necessary for the implementation of the AVCP system are laid down in the Control Plan deposited at ITC-CNR.

**Issued in San Giuliano Milanese, Italy on 22/03/2022
by ITC – CNR**

**Professor Antonio Occhiuzzi
Director of ITC-CNR**

Table A1: Panel dimensions and tolerances.

Dimension (-) ^(a)	Nominal value (mm)	Tolerance (mm)
Height of EPS	Depending on the inter-storey height	± 5
Width of EPS	1120	± 5
Average thickness of EPS	60 ÷ 160	± 5
Height of welded fabric	Depending on the inter-storey height	n.a. ^(b)
Width of welded fabric	1165	n.a.

^(a) With reference to Figure A1.

^(b) Not available information.

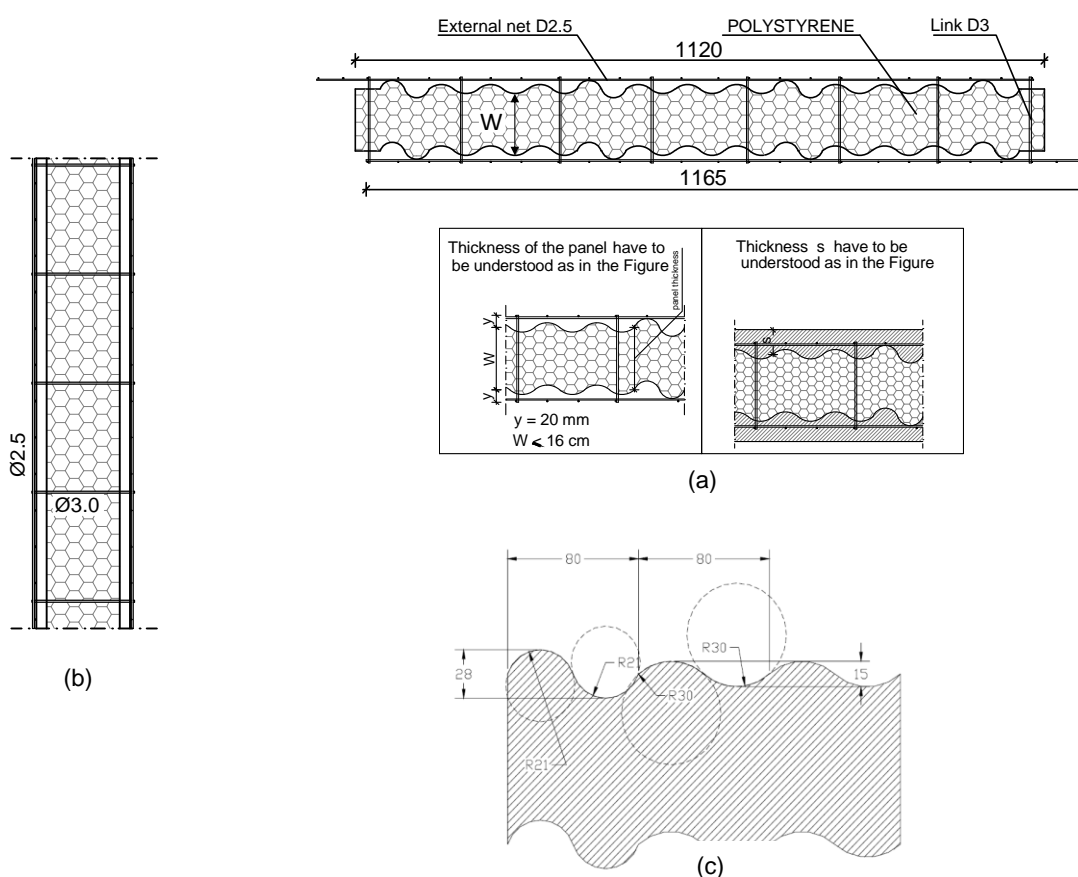
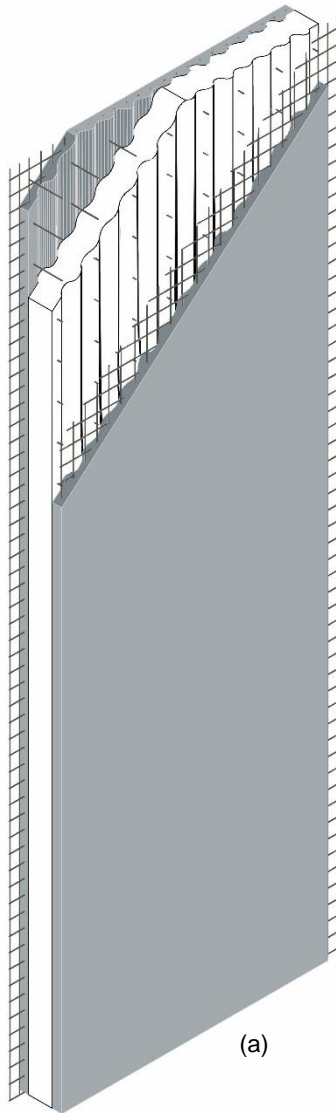

Figure A1 – Standard modular panel (dimensions in mm): horizontal section (a), vertical section (b) and detail of the EPS-core shape (c).

Pannello singolo portante Nidyon

Product Description – Constitution

**Annex A1
of ETA N° 21/1008**



(a)

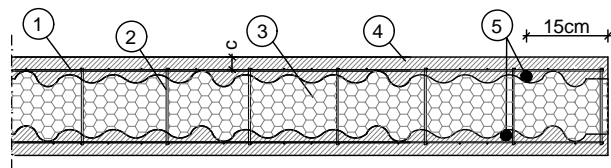

N.B. : Integrative reinforcements should be positioned at 15cm from the end of the panel

LEGEND

- ① Electrowelded net Ø2.5 mesh 50x50mm in galvanized steel
- ② Links Ø3 (No. 47/mq) in galvanized steel
- ③ Polystyrene sheet, in accord with EN 13163
- ④ Concrete (average thickness at least equal to 4 cm)
- ⑤ Vertical chain 1+1Ø12, L= Hinterstory +120 cm
- c Concrete cover
- s Average thickness of a single concrete slab (≥ 4 cm)

(b)

Figure A2 – 3D view of the whole kit (a) and horizontal section of wall edge (b).

Pannello singolo portante Nidyon

Product Description – Technology

**Annex A2
of ETA N° 21/1008**

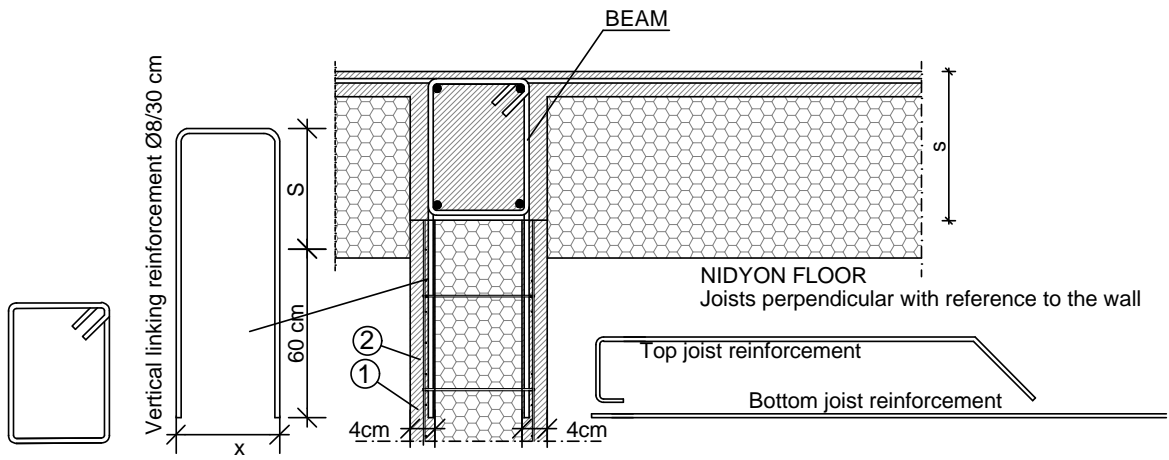

Figure A3 – Roof connection.

LEGEND

- ① CONCRETE (average thickness at least equal to 4 cm)
- ② VERTICAL LINKING REINFORCEMENT
- ⓧ EXTERNAL WIDTH OF LINKING REINFORCEMENT (x= thickness of polystyrene sheet + 2cm)
- Ⓢ TOP/BOTTOM BEAM DEPTH

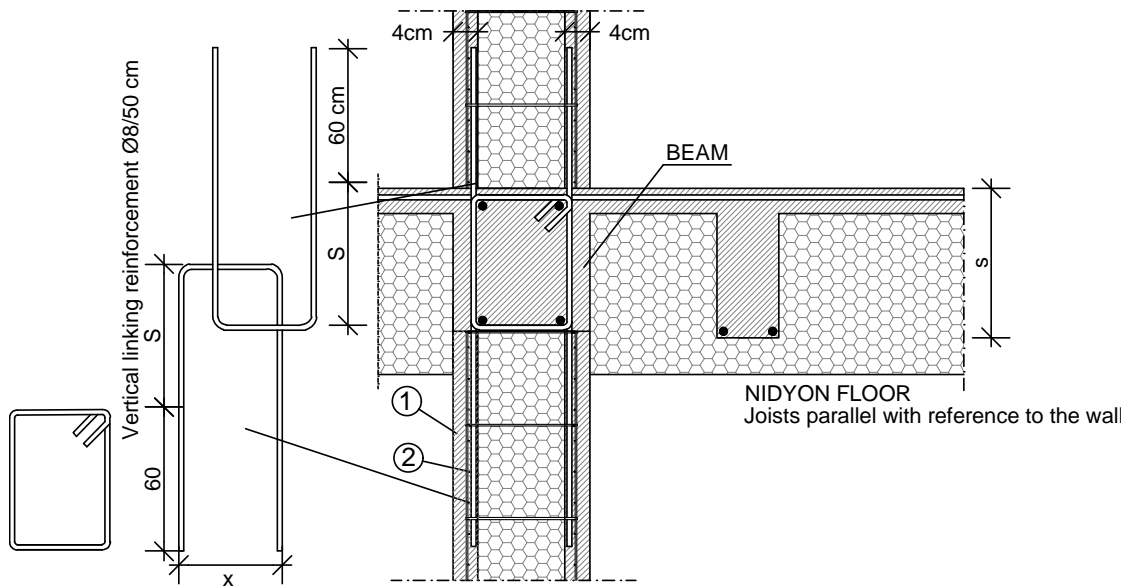

Figure A4 – Floor connection.

Pannello singolo portante Nidyon

Product Description – Connections

**Annex A3/1
of ETA N° 21/1008**

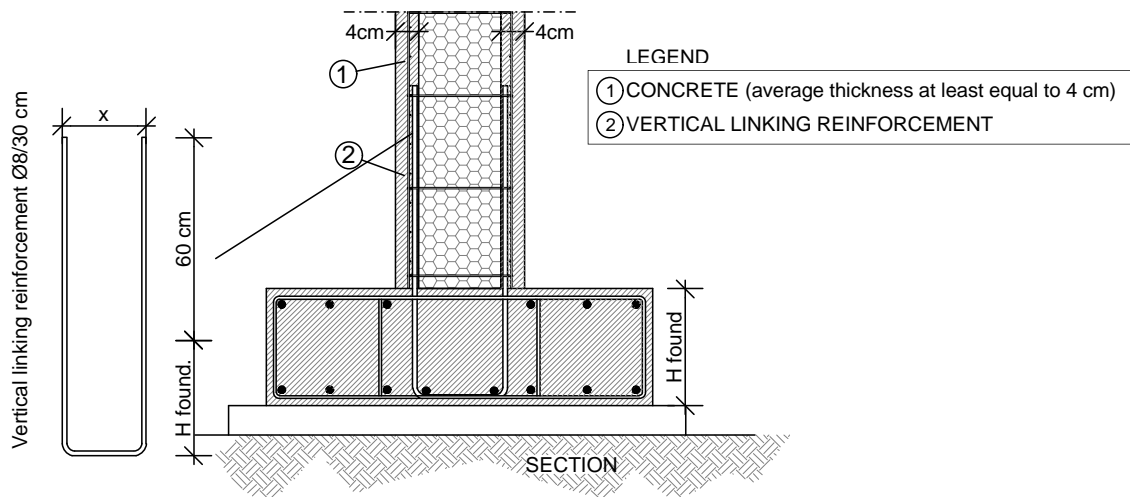

Figure A5 – Foundation connection.

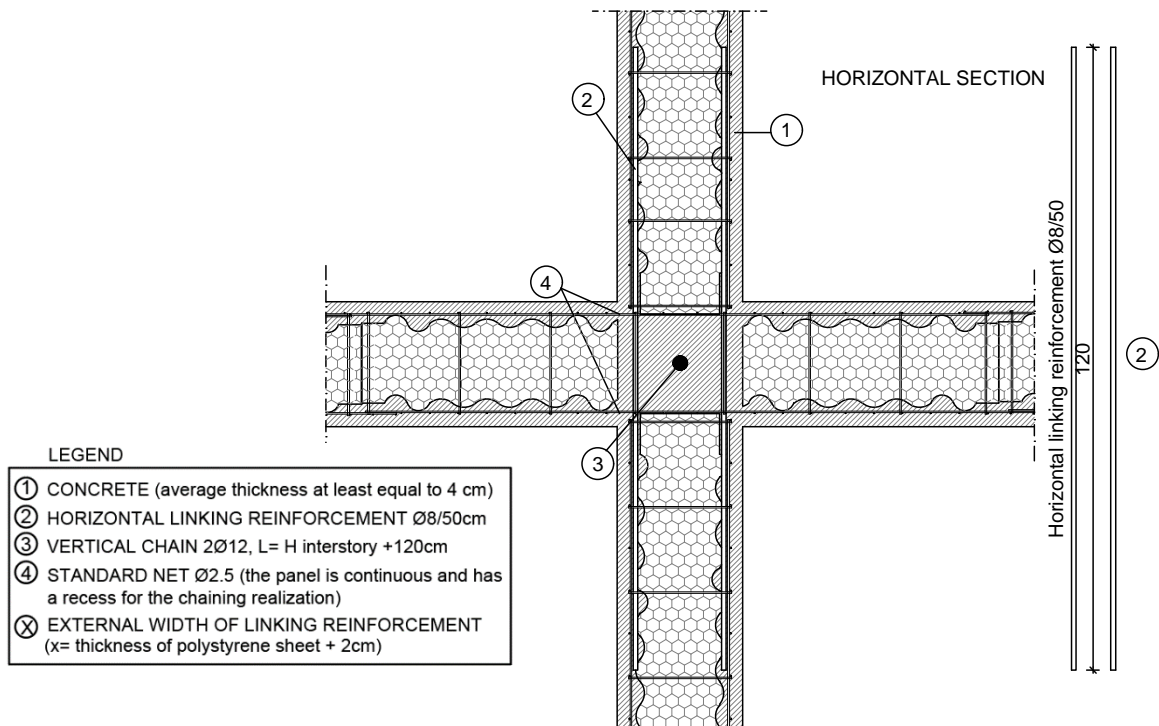

Figure A6 – Four-way connection.

Pannello singolo portante Nidyon

Product Description – Connections

**Annex A3/2
of ETA N° 21/1008**

HORIZONTAL SECTION

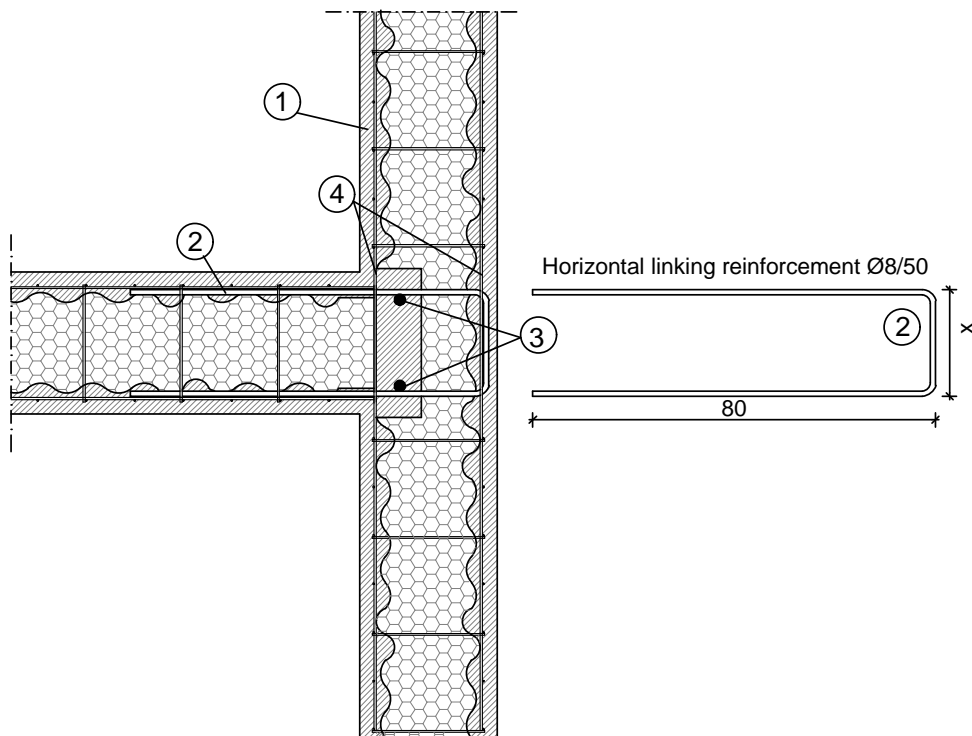

LEGEND

- ① CONCRETE (average thickness at least equal to 4 cm)
- ② HORIZONTAL LINKING REINFORCEMENT Ø8/50cm
- ③ VERTICAL CHAIN 2Ø12, L= H interstory +120cm
- ④ STANDARD NET Ø2.5 (the panel is continuous and has a recess for the chaining realization)
- ⊗ EXTERNAL WIDTH OF LINKING REINFORCEMENT (x= thickness of polystyrene sheet + 2cm)

Figure A7 – Three-way connection.

Pannello singolo portante Nidyon

Product Description – Connections

**Annex A3/3
of ETA N° 21/1008**

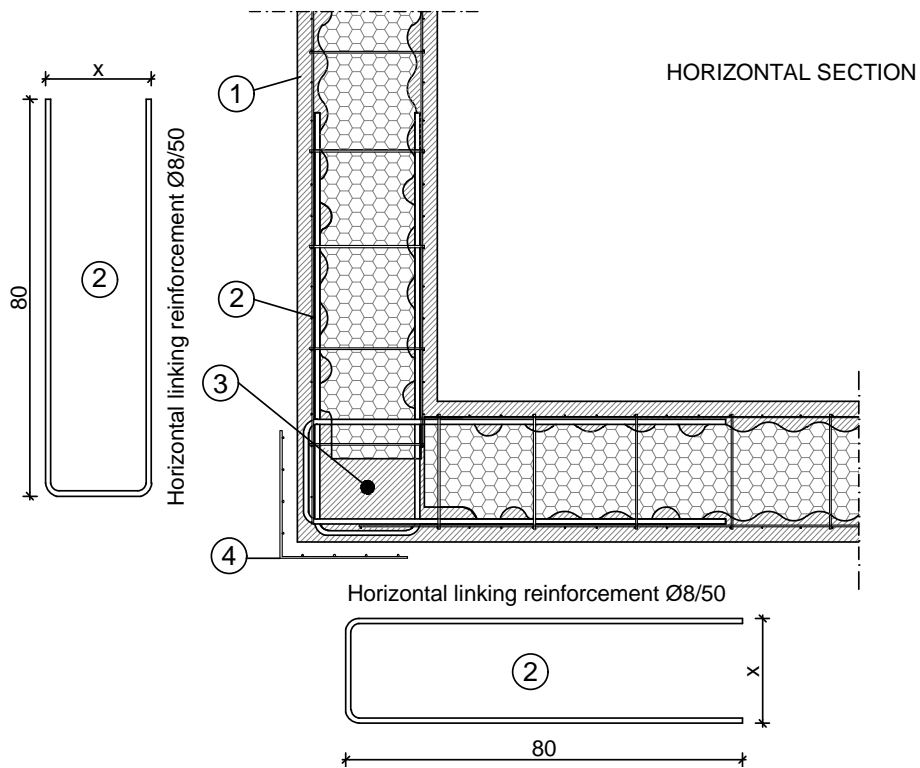

LEGEND

- ① CONCRETE (average thickness at least equal to 4 cm)
- ② HORIZONTAL LINKING REINFORCEMENT Ø8/50cm
- ③ VERTICAL CHAIN 1Ø16, L= H interstory +120cm
- ④ STANDARD NET Ø2.5 (the panel is continuous and has a recess for the chaining realization)
- ⊗ EXTERNAL WIDTH OF LINKING REINFORCEMENT (x= thickness of polystyrene sheet + 2cm)

Figure A8 – Two-way connection.

Pannello singolo portante Nidyon

Product Description – Connections

**Annex A3/4
of ETA N° 21/1008**

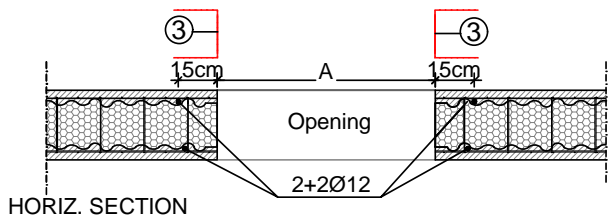
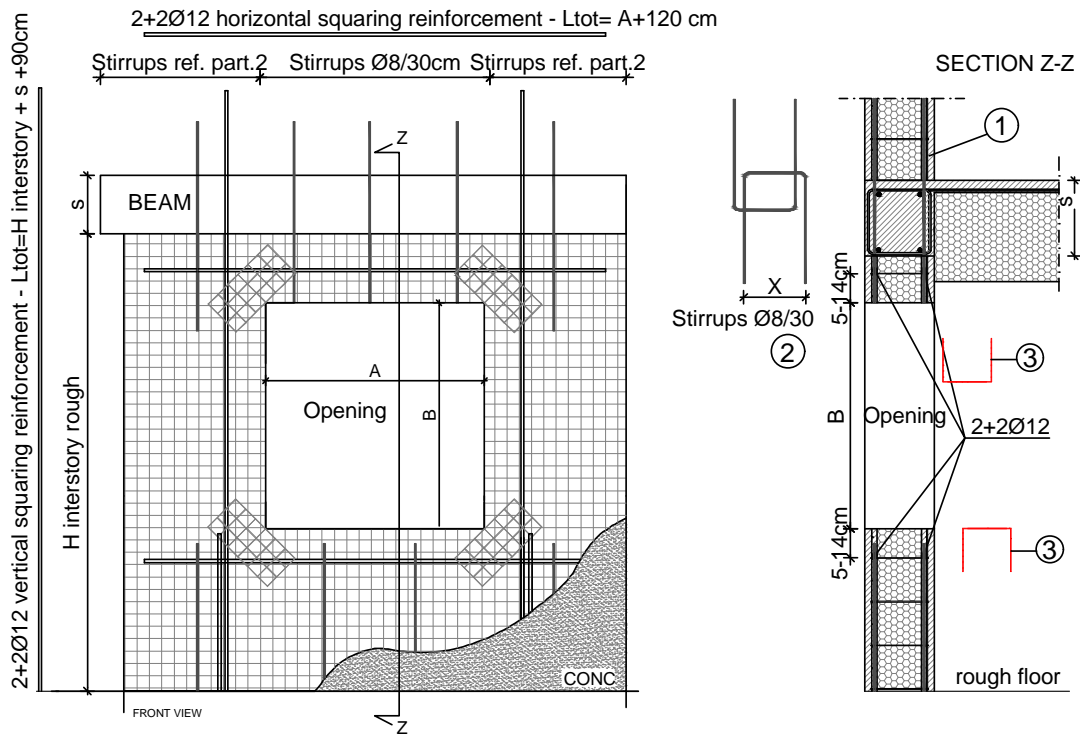

LEGEND

- ① CONCRETE (average thickness at least equal to 4 cm)
- ② CONNECTION STIRRUPS
- ③ "Mesh for plaster" (to be applied in the finishing phase)
- ⓧ EXTERNAL WIDTH OF LINKING REINFORCEMENT (x= thickness of polystyrene sheet + 2cm)
- Ⓢ THICKNESS FLOOR ROUGH

N.B. : Integrative squaring reinforcement should be positioned at 15cm from the end of the panel

Figure A9 – Window squaring.

Pannello singolo portante Nidyon

Product Description – Openings' reinforcing squaring: window

**Annex A4
of ETA N° 21/1008**

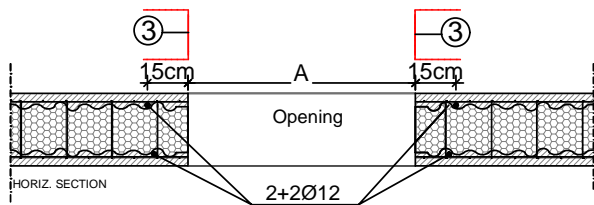
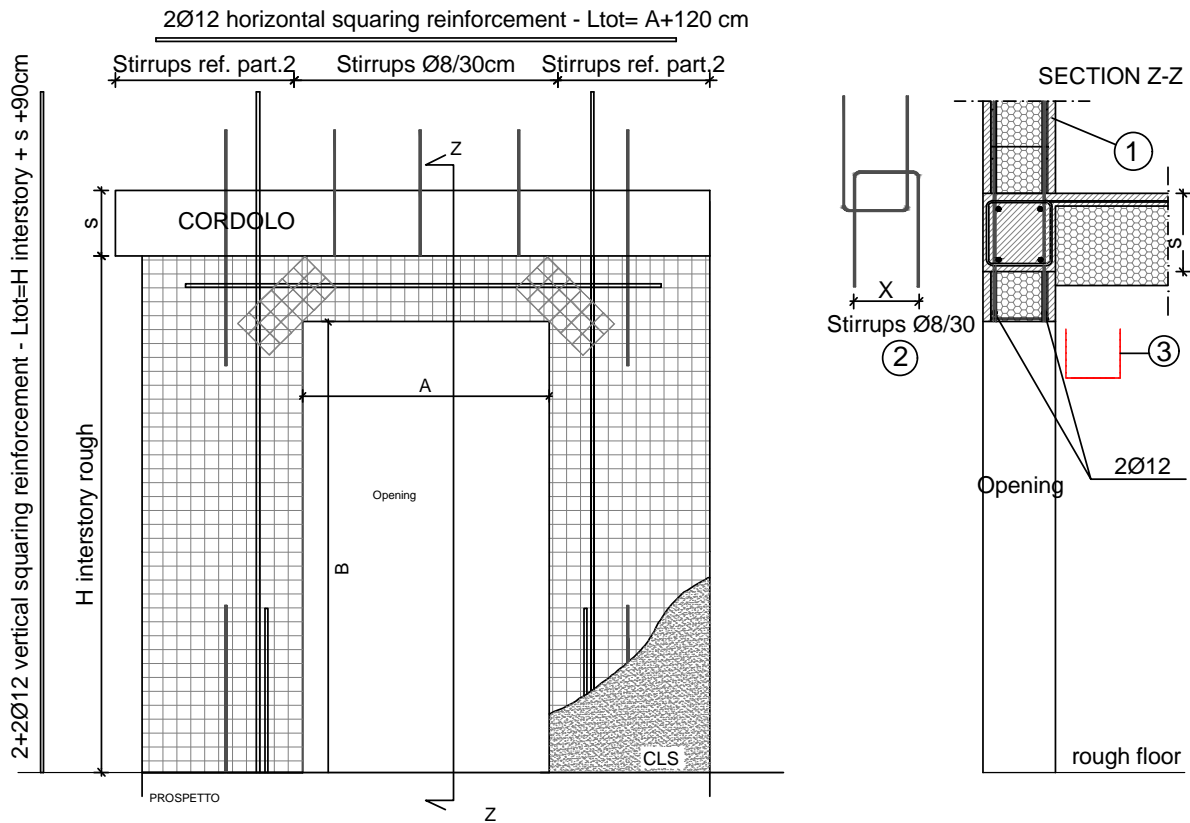

LEGEND

- ① CONCRETE (average thickness at least equal to 4 cm)
- ② CONNECTION STIRRUPS
- ③ "Mesh for plaster" (to be applied in the finishing phase)
- x EXTERNAL WIDTH OF LINKING REINFORCEMENT (x= thickness of polystyrene sheet + 2cm)
- s THICKNESS FLOOR ROUGH

N.B. : Integrative squaring reinforcement should be positioned at 15cm from the end of the panel

Figure A10 – Door squaring.

Pannello singolo portante Nidyon

Product Description – Openings' reinforcing squaring: door

**Annex A5
of ETA N° 21/1008**

INSTALLATION INSTRUCTIONS

Without derogating by the construction details outlined in Annex A, the practical use of Nidyon panels can be optimized by each designer. However, the experience gained over the years should follow some basic instructions, as reported in the followings.

Connection at the foundation

Structure foundations are built using traditional methods (foundation beams or slabs, depending on the specific features of the soil, see Figure B1a). To ensure an effective connection between the walls and the foundations, the foundations present steel bars (“runners”, typically 1+1 Φ 8/50cm or 1+1 Φ 8/30cm and properly anchored) which extend upwards. The runners are designed and positioned so that, after panels are placed, they are inserted between the polystyrene and the meshes.

The runners shall be firmly connected to the foundation by means of the positioning within the reinforcement of the foundation or, after the casting of concrete, through a chemical fixing system (resin anchors, as in Figure B1b).

It is important that reinforcements are in the right position, determined tracing the lines of the walls and taking in account the overall wall thickness (with 4+4 cm on each side).

The wall panels (identified as type and number through a special marking) are placed starting from a corner of the structure and, after tracing it on the ground, following the assembling order, as indicated in the suitable production abacus.

In the overlapping zones, steel meshes shall be carefully tied to the runners, if possible, by means of metal clips placed using a pneumatic staple machine or through a classical binding of steel wires.



(a)



(b)

Figure B1 – Installation of the panel-foundation connection.

Pannello singolo portante Nidyon

Intended Use – Installation instructions

**Annex B1/1
of ETA N° 21/1008**

Preliminary operations

The placing of the panels must be done with a good precision aimed to avoid hypothetical misalignments or out of plumb. It is suggested to place a reference board at the top of the panels, corresponding to the architectural exterior line of the finite wall, to realize the plumb by means of a system of wooden or steel props, tied at the base and at the reference board.

At the base and on the top of the panels, at the vertical wall junctions and close of the openings, before application of concrete, the additional reinforcements must be placed taking care to bind them to the structural nets.

Creation of the chases and placement of the canalizations for the systems

The placement of canalizations and accessories for the electrical and hydro-thermo-health systems follows the panel and reinforcement positioning, before concrete casting. The chases can be created into the EPS through a hot air gun (e.g. using a paint-remover). If rigid pipes must be placed, it can be necessary to cut the net partially. Such areas should then be replaced through a overlapping and by fixing an additional reinforcement net.

Placing the opening frames

It is possible to place the opening frame before the placing of concrete, incorporating into the casting also the relative anchorage stirrups. The result will be a “cleaner” hooking, allowing to avoid any supplementary works.



Figure B2 – Alignment operations of panels.

Pannello singolo portante Nidyon

Intended Use – Installation instructions

**Annex B1/2
of ETA N° 21/1008**

Concrete pouring

Concrete casting of walls shall be made using a “sprit beton” method, i.e. by means of the spraying of concrete (using a nozzle fed by a compressed air turbo-pump) until an overall thickness equal to 4 cm on each side of panels is reached.

Ordinary concrete can be used, both prepacked and made on site. However, a mix design with a selected granulometry (maximum aggregate dimension equal to 3 mm) is needed.

The finishing phase shall be carried out after that a suitable hardening of concrete is obtained. In the connections (junctions between perpendicular walls and between walls and inter-storey floors), special plaster nets or gauzes shall be previously placed, in order to control hypothetical shrinkage cracks that could appear where the structural net is discontinuous.

For the same reason, where openings (doors and windows) are located, it is necessary to place C shaped plaster nets or gauzes, so to bind the area where the finishing concrete bonds with the polystyrene directly.

For multilevel buildings, the sequence of the phases outlined above shall be repeated for each floor.

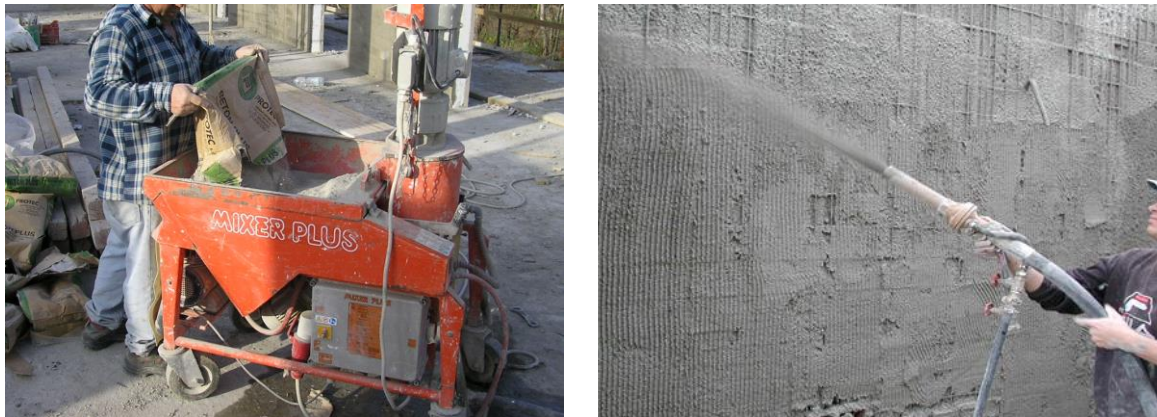

Figure B3 –Concrete pouring by means of “sprit-beton” method.

Pannello singolo portante Nidyon

Intended Use – Installation instructions

**Annex B1/3
of ETA N° 21/1008**

Table C1: Performance of full-scale walls subjected to cyclic in-plane shear tests.

	Specimen							
	1	2	3	4	5	6	7	8
Width [m]	3.0	3.0	3.0	3.0	3.0	3.0	4.0	4.0
Height [m]	3.0	3.0	3.0	3.0	3.0	3.0	3.0	3.0
Aspect ratio [-]	1.00	1.00	1.00	1.00	1.00	1.00	0.75	0.75
Opening ^(a)	-	-	W	W	D	D	-	-
Width of the opening [m]	-	-	1.0	1.0	1.0	1.0	-	-
Height of opening [m]	-	-	1.0	1.0	2.0	2.0	-	-
Thickness of the shotcrete [mm] ^(b)	40	40	40	40	40	40	40	40
EPS thickness [mm]	100	100	100	100	100	100	100	100
Concrete compressive strength [MPa] ^(c)	26.0	26.0	26.0	26.0	25.5	25.5	25.5	25.5
Maximum aggregate size [mm]	3.0	3.0	3.0	3.0	3.0	3.0	3.0	3.0
Wire diameter of welded fabric [mm] ^(d)	2.5	2.5	2.5	2.5	2.5	2.5	2.5	2.5
Pitch of welded fabric [mm] ^(d)	50.0	50.0	50.0	50.0	50.0	50.0	50.0	50.0
Applied vertical load [kN]	50.0	100.0	50.0	100.0	50.0	100.0	50.0	100.0
Initial stiffness [kN/m]	48193	56088	40158	43719	32542	32478	67529	71254
Cracking shear force [kN] ^(e)	137.4	159.9	114.5	124.6	93.7	100.8	192.8	203.1
Maximum displacement at cracking [mm] ^(e)	2.85	2.85	2.85	2.85	2.85	2.85	2.85	2.85
Yielding shear force [kN] ^(f)	215.0	235.3	174.8	183.1	152.8	214.06	275.7	288.6
Maximum displacement at yielding [mm] ^(f)	5.53	4.63	6.27	5.81	6.40	8.05	4.23	4.61
Maximum shear force [kN]	294.5	299.7	296.8	288.0	249.2	285.8	324.1	352.7
Maximum displacement at collapse [mm] ^(g)	38.0	27.0	44.0	44.0	30.2	26.6	25.5	24.4
Experimental displacement ductility [-] ^(h)	6.9	5.8	7.0	7.6	4.7	3.3	6.0	5.3

^(a) Opening placed in the centre of the panel: window- (W) or door- (D) type.

^(b) Intended as thickness of shotcrete on each side of the panel.

^(c) Mean value of concrete cylindrical compressive strength experimentally assessed according to EN 206-1.

^(d) Diameter and pitch of the welded fabric are identical in both directions (i.e., horizontal and vertical).

^(e) Corresponding to limit values of force and displacement of the first cycle in which first cracking was observed.

^(f) Determined as corresponding to the first yielding of vertical steel bars.

^(g) Horizontal displacement measured at the top of the specimens corresponding to a decrease of 20% of the maximum recorded shear force.

^(h) Ratio of the maximum displacement at collapse to the maximum displacement at yielding.

Pannello singolo portante Nidyon

Performances – Resistance to flexure and seismic actions

**Annex C1
of ETA N° 21/1008**

Table C2: Performance of panels in diagonal compression tests.

Diagonal compression	
Width [m]	1120
Height [m]	1120
Thickness of the shotcrete [mm]	40
EPS thickness [mm]	60
Wire diameter of welded fabric [mm] ^(b)	3
Pitch of welded fabric [mm] ^(b)	50
Concrete compressive strength [MPa] ^(c)	26
Maximum aggregate size [mm]	3
Ultimate load, T_{iu} [kN] ^(d)	488.3

^(a) Intended as thickness of shotcrete on each side of the panel.

^(b) Diameter and pitch of the welded fabric are identical in both directions (i.e., horizontal and vertical).

^(c) Mean value of concrete cylindrical compressive strength experimentally assessed according to EN 206-1.

^(d) Mean value obtained from the experimental tests.

Table C3: Performance of panels laminar shear tests.

Laminar shear	
Width [m]	1120
Height of panel [m]	1500
Thickness of the shotcrete [mm] ^(a)	40
Wire diameter of welded fabric [mm] ^(b)	3
Pitch of welded fabric [mm] ^(b)	50
Concrete compressive strength [MPa] ^(c)	26
Maximum aggregate size [mm]	3
EPS thickness [mm]	60
Initial in-plane stiffness, K_{iDe} [kN/m] ^(d)	94356
Ultimate load, T_{iDu} [kN] ^(d)	208.4
EPS thickness [mm]	180
Initial in-plane stiffness, K_{iDe} [kN/m] ^(d)	44936
Ultimate load, T_{iDu} [kN] ^(d)	132.0
EPS thickness [mm]	200
Initial in-plane stiffness, K_{iDe} [kN/m] ^(d)	39610
Ultimate load, T_{iDu} [kN] ^(d)	115.7

^(a) Intended as thickness of shotcrete on each side of the panel.

^(b) Diameter and pitch of the welded fabric are identical in both directions (i.e., horizontal and vertical).

^(c) Mean value of concrete cylindrical compressive strength experimentally assessed according to EN 206-1.

^(d) Mean values obtained from the experimental tests.

Pannello singolo portante Nidyon

Performances – Resistance to shear

**Annex C2
of ETA N° 21/1008**

Table C4: Performance of panels under centred compression tests.

Centred compression (buckling)	
Width [m]	1120
Height [m]	2900
Thickness of the shotcrete [mm] ^(a)	40
EPS thickness [mm]	60
Wire diameter of welded fabric [mm] ^(b)	3
Pitch of welded fabric [mm] ^(b)	50
Concrete compressive strength [MPa] ^(c)	26
Maximum aggregate size [mm]	3
Ultimate load, N _{ibu} [kN]	1429

^(a) Intended as thickness of shotcrete on each side of the panel.

^(b) Diameter and pitch of the welded fabric are identical in both directions (i.e., horizontal and vertical).

^(c) Mean value of concrete cylindrical compressive strength experimentally assessed according to EN 206-1.

Pannello singolo portante Nidyon

Performances – Resistance to compression

**Annex C3
of ETA N° 21/1008**